



**Product Name: SATURN**

## General information

- This luminaire must be installed in accordance with the latest edition of the IET Wiring Regulations and local Building Regulation by a qualified competent person.
- The mains power supply must be turned off before inspection, installation or removal of the luminaire, ensuring that the supply is locked off to prevent inadvertently switching the supply on.
- It is the installer's responsibility to ensure that the installation is suitable for the total load of the luminaire(s). The supply cable fuses/circuit breakers must be correctly rated for the electrical load and taking into account for any transient inrush currents that may occur.
- It is the installer's responsibility to ensure that the environmental operating and storage conditions are complied with and that any fire risks are considered.
- Do not perform insulation strength or insulation resistance tests on the installation with the luminaire(s) connected, this can damage the luminaires and give erroneous readings.
- Do not loop-in supply cables at the luminaire supply terminals unless there is provision for 2-way connection at the terminals.
- The light source contained in this luminaire must only be replaced by TamLite Lighting or an appointed service agent.
- Emergency lighting luminaires must be installed and maintained in accordance with the emergency lighting standard BS 5266-1.
- To ensure that the product warranty remains valid, the luminaire must be installed and maintained in accordance with these installation instructions and the product must not be modified in any way.

-  Luminaires marked with this symbol must not be covered with thermally insulating material.
-  This symbol on covers over light sources indicates dangerous live parts do not operate the luminaire with this cover removed.

## Dimensions

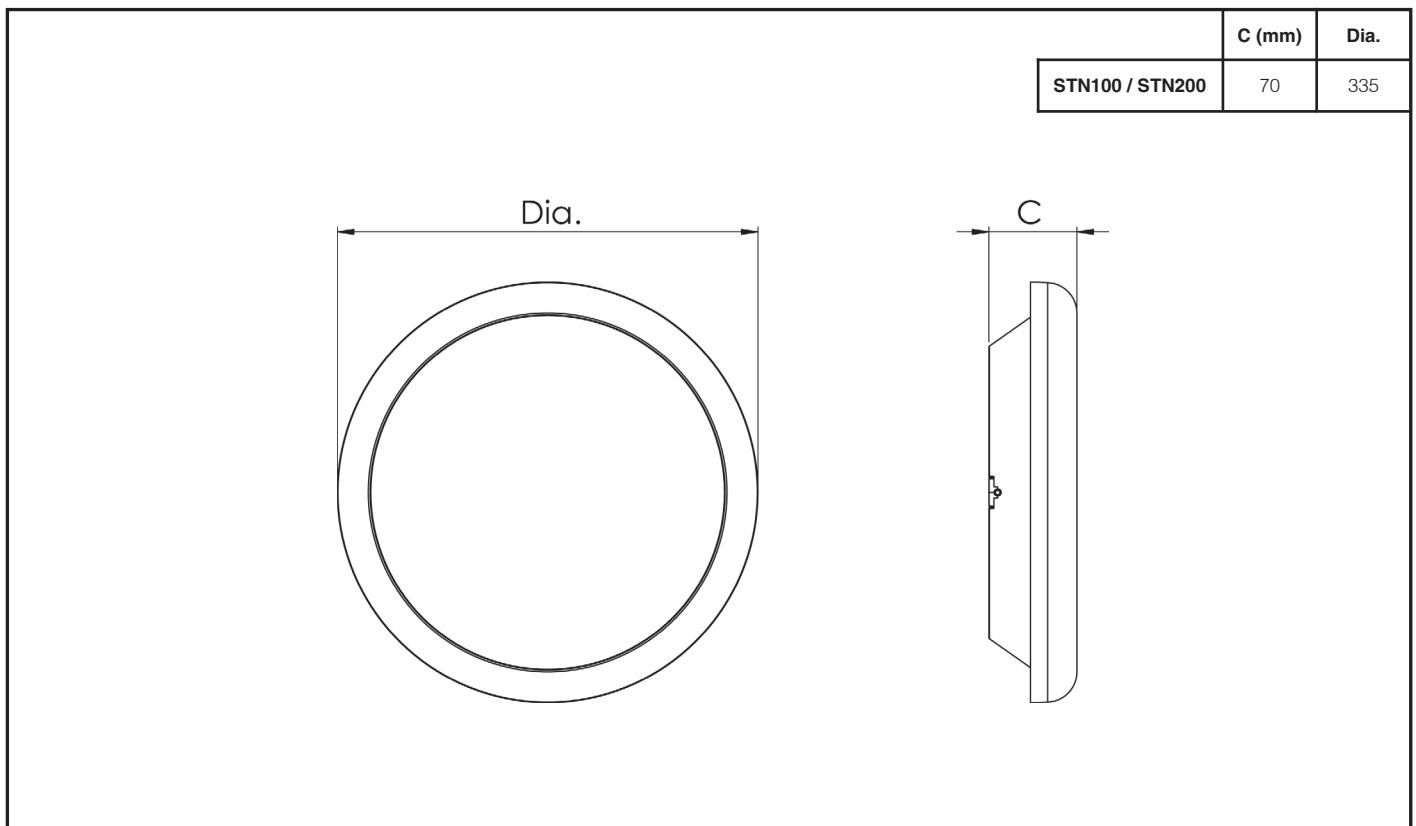

**Page 1 of 3**

Tamlite Technical  
Stafford Park 12,  
Telford, Shropshire,  
TF3 3BJ

+44(0)1952 292441  
technical@tam-lite.co.uk  
Document No: V2



Product Name: SATURN

<p>1</p> <p>Remove the product from its packaging.</p>	<p>2</p> <p>Loosen the two screws and remove the mounting bracket.</p>
<p>3</p> <p>Secure the bracket to the mounting surface with appropriate hardware.</p>	<p>4</p> <p>Release the four clips and remove the front trim.</p>
<p>5</p> <p>Loosen the four screws and remove the diffuser.</p>	<p>6</p> <p>Loosen the four screws and disconnect the wire to remove the LED board.</p>
<p>7</p> <p>Bring incoming supply cable through the cable entry point.</p>	<p>8</p> <p>Terminations shown for standard and emergency variants.</p>

Page 2 of 3

Tamlite Technical  
 Stafford Park 12,  
 Telford, Shropshire,  
 TF3 3BJ

+44(0)1952 292441  
 technical@tamllite.co.uk  
 Document No: V2

			220-240V 50/60Hz		IP65	IK08	TP(a)	ta 0°C to 25°C 5°C to 25°C for M3 variants
--	--	--	---------------------	--	------	------	-------	---

Product Name: SATURN

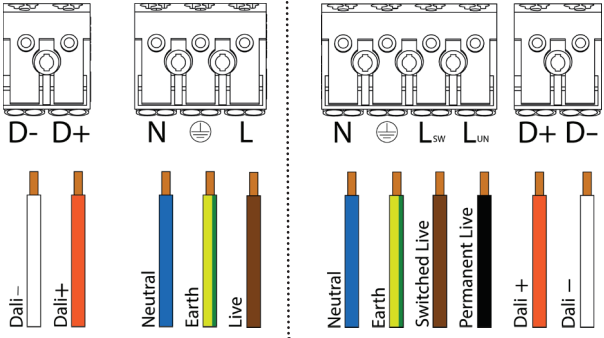
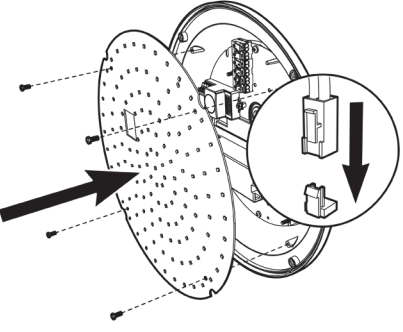
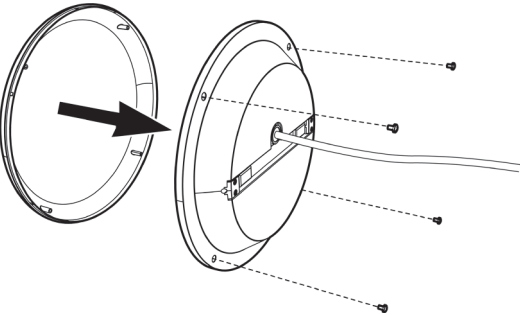
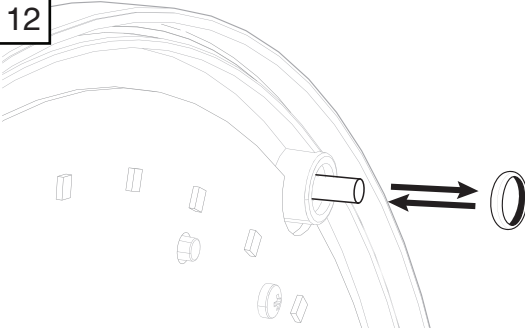
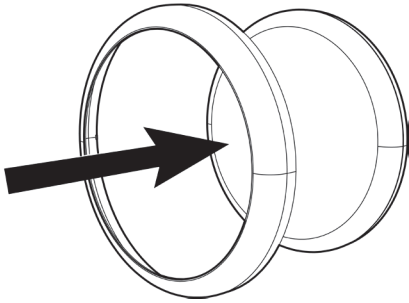
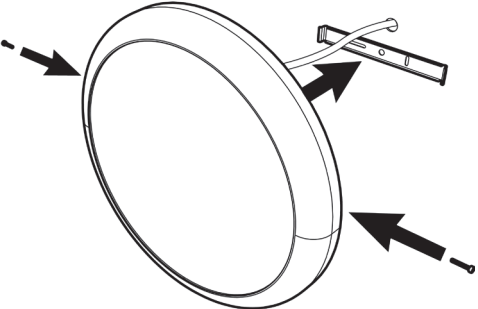
<p><b>9</b></p>  <p>Terminations shown for DALI dimmable and DALI emergency variants.</p>	<p><b>10</b></p>  <p>Reconnect the LED wire and re-fit the LED board.</p>
<p><b>11</b></p>  <p>Re-attach the diffuser and tighten the four screws.</p>	<p><b>12</b></p>  <p>Additional washers are included if required, attach the rubber washer to interior side prior to reassembling luminaire. These are required to maintain the IP65 rating.</p>
<p><b>13</b></p>  <p>Clip the front trim back in to place.</p>	<p><b>14</b></p>  <p>Position the luminaire over the bracket and tighten the screws to secure in place.</p>